

# 520AJ HC3

ARTICULATING HI-CAPACITY BOOM LIFT

BOOM LIFT

**JLG**<sup>®</sup>

## Performance

Platform Height	16.00 m
Working Height	18.00 m
Horizontal Outreach	10.00 m
Up and Over Height	7.30 m
Swing	355 Degrees Non-Continuous
Platform Capacity	
Restricted	340/454 kg
Unrestricted	300 kg
Platform Rotator	180 Degrees Hydraulic
Jib	1.24 m
Range of Articulation	145 Degrees (+76, -69)
Weight*	8.850 kg
Max. Ground Bearing Pressure	7.21 kg/cm <sup>2</sup>
Drive Speed	6.8 km/h
Gradeability	45%
Tilt Cut Out	5 Degrees
Turning Radius	
Outside	4.78 m
Inside	2.06 m

## Standard Specifications

### Power Source

Diesel Engine	Deutz D2011L03 Tier 4i 49 hp 36.4 kW
Fuel Tank Capacity	60.6 L

### Hydraulic System

System Capacity	65.5 L
Tank Capacity	56.8 L
Auxiliary Power	12V-DC

### Tyres

Standard	Foam Filled Non-marking
----------	-------------------------

## Standard Features

- 1.24 m Articulating Jib
- 5.5 kVA Generator including Outlets to Platform and ELCB
- 0.76 x 1.83 m Side Entry Platform
- 180 Degree Hydraulic Platform Rotator
- Platform Console Machine Status Light Panel\*
- 5 Degree Tilt Alarm/Indicator Light
- Swing Out Engine Tray
- 12V-DC Auxiliary Power
- Hourmeter
- Proportional Controls
- Interactive Display at Ground Controls
- Control ADE<sup>®</sup> System
- Lifting/Tie Down Lugs
- Horn
- Four-Wheel Hydrostatic Drive
- Inward Self-Closing Swing Gate
- Flashing Amber Beacon
- Operator Tool Tray
- Oscillating Axle
- Motion Alarm
- Reduced Time to Full Height
- Load Sensing System
- SkyGuard SkyLine™

3 Capacity Zones - Each rated for 3 occupants + tools/materials



**HC3**

## Accessories & Options

- 36 x 72 in. (0.91 x 1.83 m) Platform
- Fire Extinguisher
- White Noise (Squawker) Motion Alarm
- SkySense™

\*Provides indicator lights at platform and ground control consoles for system distress, low fuel, 5 degree tilt light, and foot switch status.

Note: Some options may increase lead time, and some option combinations may not be available.

Additional accessories and options available via JLG Aftermarket.

# 520AJ HC3

ARTICULATING HI-CAPACITY BOOM LIFT

BOOM LIFT



## Dimensions

All dimensions are approximate.

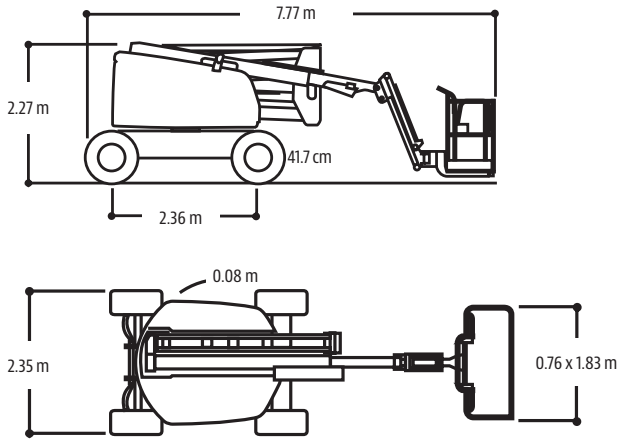

## Reach Diagrams

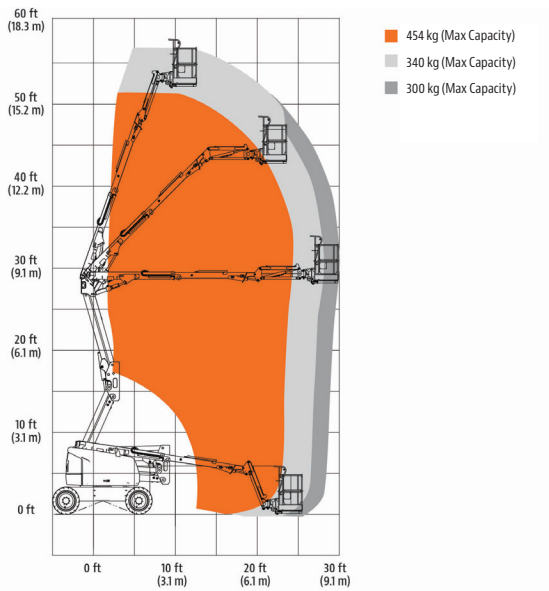

## The JLG "1 & 5" Warranty

We provide coverage for one (1) full year, and cover all specified major structural components for five (5) years. Due to continuous product improvements, we reserve the right to make specification and/or equipment changes without prior notification. This machine meets or exceeds applicable ANSI and CSA requirements based on machine configuration as originally manufactured for intended applications. Please reference the serial number plate on the machine for additional information.

R0324

JLG Industries (Australia)  
358 Park Road  
Regents Park, NSW 2143  
Telephone 02 8718 6300  
Fax 02 8718 6377  
[www.jlg.com.au](http://www.jlg.com.au)

An Oshkosh Corporation Company